

THIS DRAWING IS UNPUBLISHED.

RELEASED FOR PUBLICATION

© COPYRIGHT - By -

ALL RIGHTS RESERVED.

LOC	DIST	REVISIONS			
P	LTR	DESCRIPTION	DATE	DWN	APVD
AF	50	F	REVISED PER ECR-12-013518	23NOV2012	KH PD

- 1 CONTINUOUS STRIP ON REELS.
- 2 ACCEPTS [#20-#16] AWG. WIRE SIZE
- 3 INSULATION RANGE TO BE 2.79-4.32 [.110-.170] DIA
- 4 FEED IS 16.38±0.13 [.645±.005]
- 5 MATING TAB THK IS 0.81±0.025 [.032±.001].
- △6 PREPRODUCTION - FASR REQUIRED

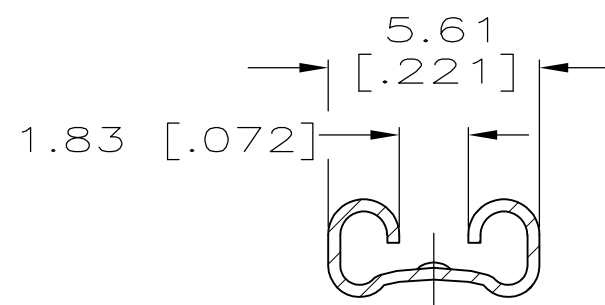
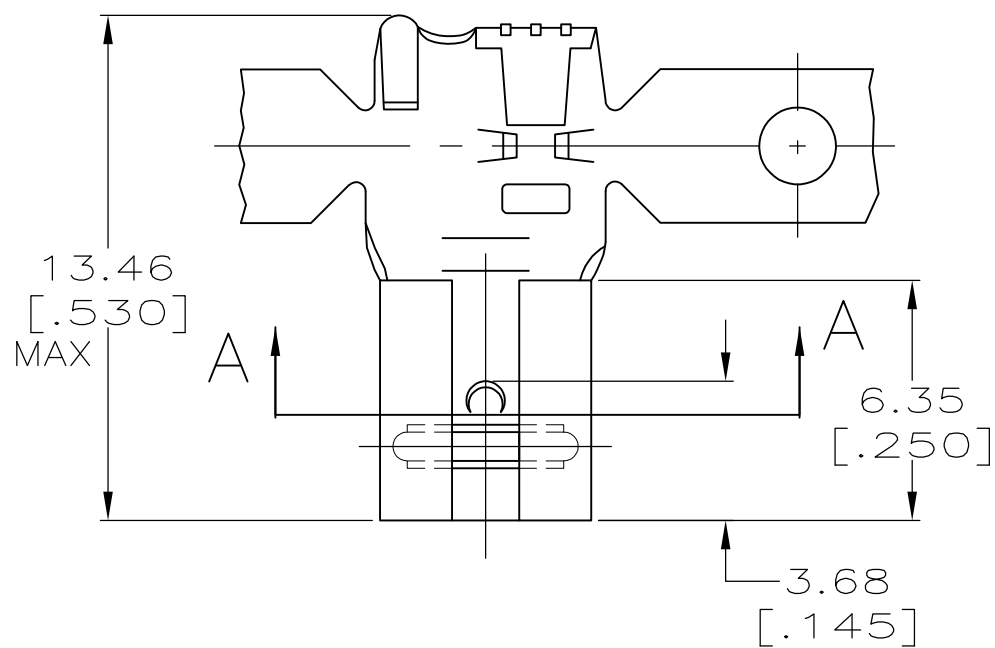

SECTION A-A

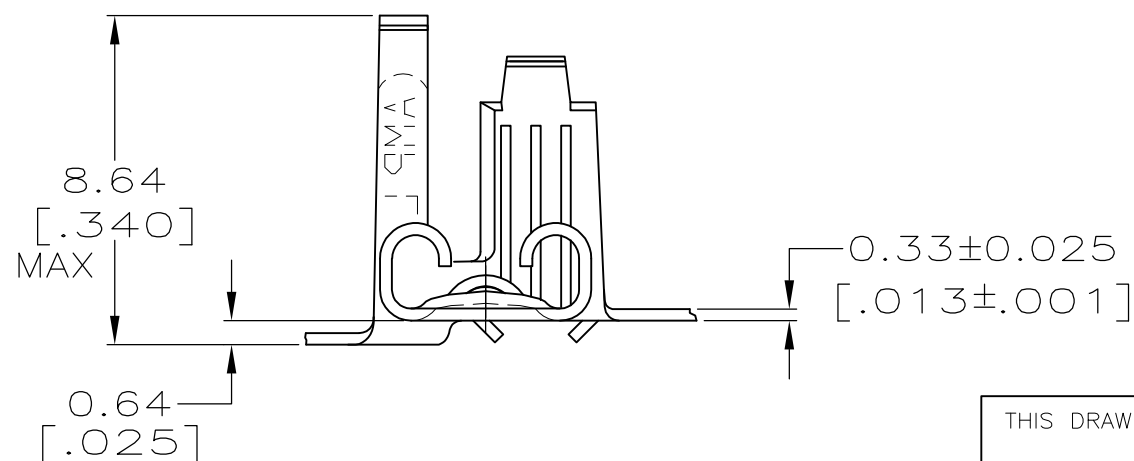

TIN	H04 PHOS BRONZE	△6 63748-3
TIN	BRASS	63748-2
---	BRASS	63748-1
FINISH	MATERIAL	PART NO.

THIS DRAWING IS A CONTROLLED DOCUMENT.		DWN	JR RUTH	7/27/93	STE TE Connectivity		
DIMENSIONS: mm [INCHES]		CHK	MS FEHER	7/27/93			
TOLERANCES UNLESS OTHERWISE SPECIFIED:		APVD	R KUZO	7/27/93	NAME		
0 PLC	± -	PRODUCT SPEC		RECEPTACLE, LIF, FASTON, FLAG, 4.75 [.187] SERIES			
1 PLC	± -	APPLICATION SPEC		SIZE	CAGE CODE	DRAWING NO	RESTRICTED TO
2 PLC	± 0.25 [.010]	MATERIAL		A3 00779		C-63748	---
3 PLC	± -	FINISH		CUSTOMER DRAWING			SCALE
4 PLC	± -	SEE TABLE		5:1			SHEET
ANGLES	± -	SEE TABLE		1 OF 1			REV
MATERIAL		SEE TABLE		F			