

LV8548MCSLDGEVB

Stepper Motor Driver Module Solution Kit Quick Start Guide Appendix

• Arduino IDE Installation

- ① Run  `arduino-1.8.4-windows.exe`
The installer is available in the USB drive provided in the Motor Driver Kit.
(To avoid software from not operating properly, please use this version and refrain from updating)
- ② Read through and agree to the terms and conditions during the setup by clicking the “I Agree” button

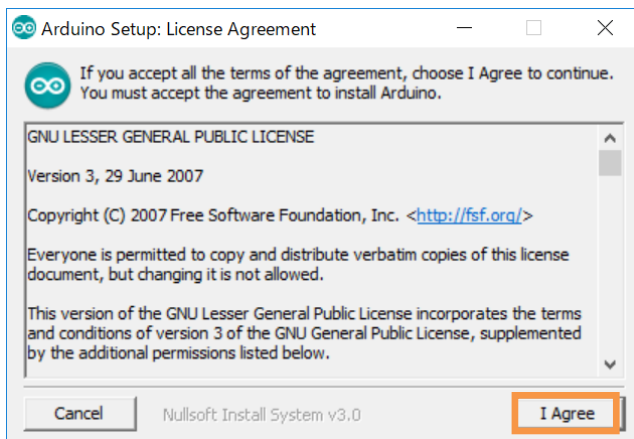

- ③ Leave the following default components to install as is and press “Next”

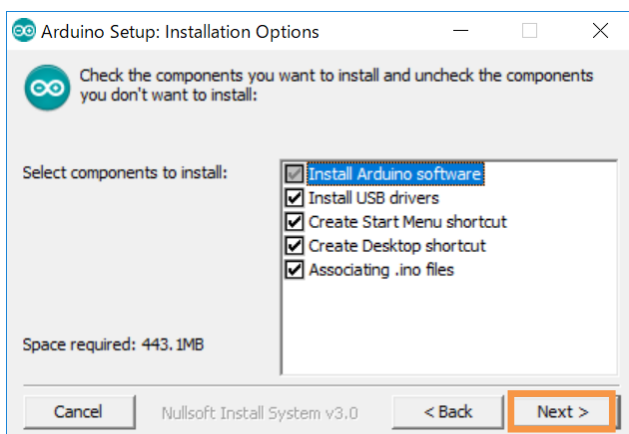

- ④ Set the install directory and press “Install”

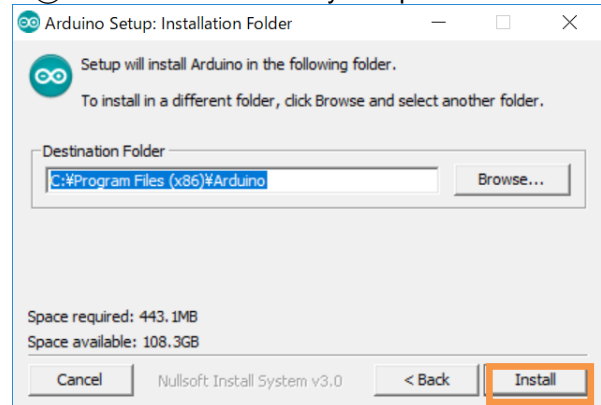

- ⑤ If prompted, please install the Arduino USB Drivers

- ✓ Arduino USB Driver
- ✓ Genuine USB Driver
- ✓ libusb-win32
- ✓ Adafruit Industries LLC Port (COM and LPT)
- ✓ Linino Port (COM and LPT)

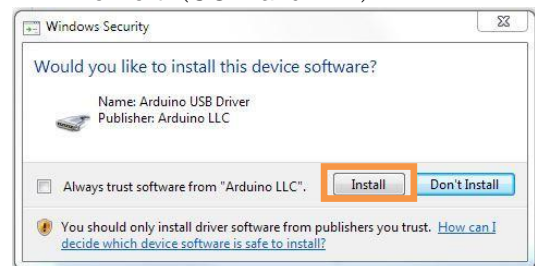

- ⑥ Below shows a completed installation for the Arduino IDE. Feel free to click “Close.”

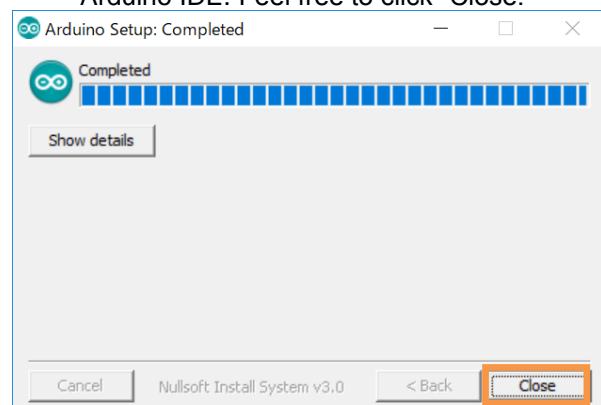

LV8548MCSLDGEVB for Stepper motor

• Supplemental GUI Content

The following step numbers correspond to the step numbers in the “How to use the GUI” section in the Quick Start Guide

⑧ Changing GUI Language

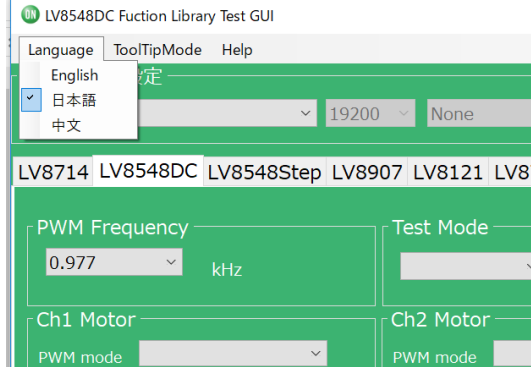

Languages can be changed from the menu on the top left of the window.

Motor driver tab languages are not changed. (Please see tool tip for translations)

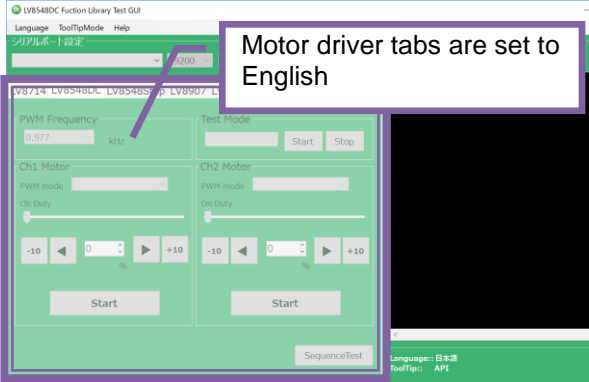

⑨ GUI Tool Tip display

The GUI sends serial data to execute API functions in the Arduino through USB.

With the API Hints turned on, hover over different buttons and settings to display descriptions and functions associated with that item.

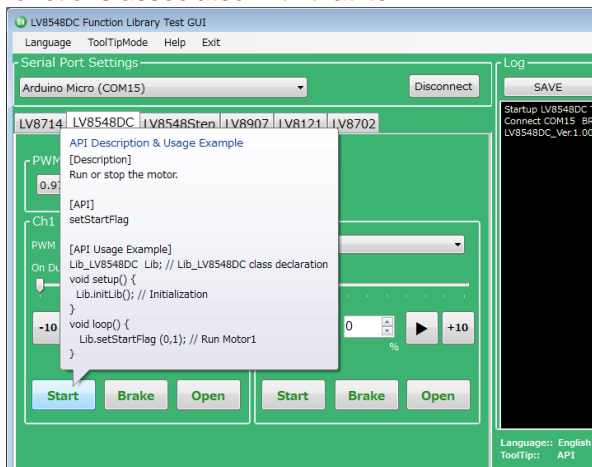

The API hints can be turned off by navigating through the ToolTipMode menu at the top of the window

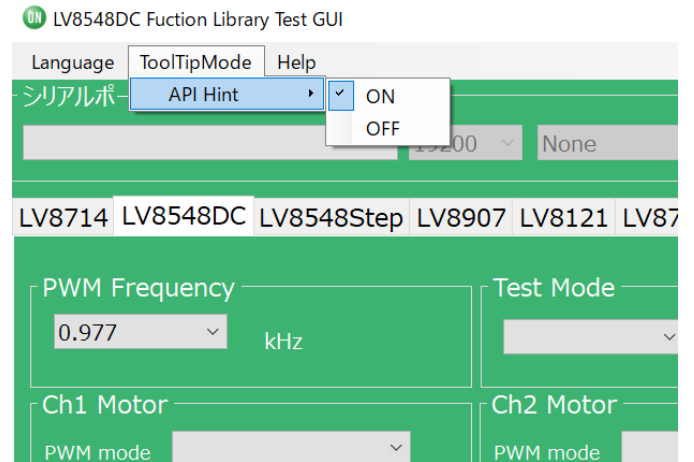

⑩ Help function

From the help menu, it is possible to view GUI and API version information, as well as serial communication details.

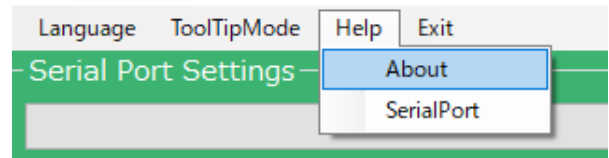

Selecting About will display the following window.

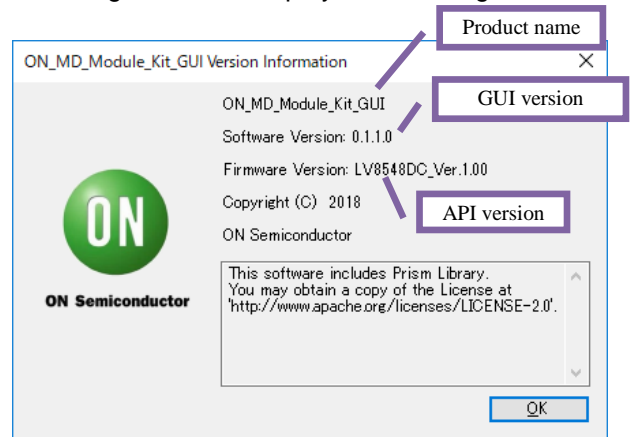

Selecting SerialPort will display the overview of serial communication.

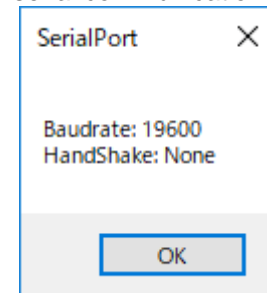

*Some screen captures are taken from different motor driver modules

LV8548MCSLDGEVB for Stepper motor

⑭ Arduino program code generation

When using the GUI, automatically generated Arduino code will be output to the log window. It is possible to export the code to an Arduino sketch (.ino) file that can be used with the Arduino IDE.

Once the automatically generated code is imported into the Arduino IDE, it is possible to mimic the procedures from the GUI.

1) Generating and writing Arduino code

Pressing Generate Program will open a save file dialog.

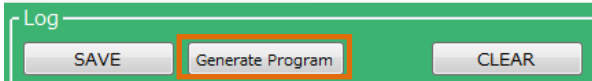

Please select the desired directory for the file to be saved (e.g. Desktop or Documents) and click Save

When using the GUI  LV8548_STEP_Program.ino is the name of the program, so a different name will need to be used to save the exported file.

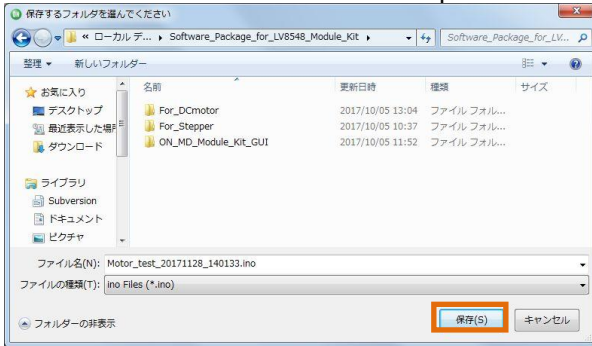

Double click the newly saved Arduino program to open the Arduino IDE.

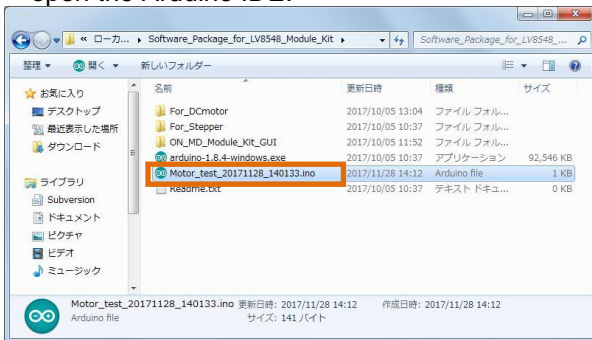

The GUI and Arduino IDE cannot be connected to a PC at the same time. To upload the Arduino program, please exit or select Disconnect in the GUI, and proceed working in the Arduino IDE.

Follow the instructions in the Quick Start Guide in P3 “Compiling the Arduino Program – Write to Arduino”

2) Using the generated Arduino program

After each API operation in the generated program, a delay(0) is inserted. By changing the value of the argument (0)* to the delay function, the user is able to freely adjust the rotation time, as well as the interval time between each API call execution. This can be used to achieve the desired stand-alone operation

* Parameter units are msec (1000th of a second). For a delay of 1 second, use delay(1000).

[Example of changing the interval time]

```
#include <LV8548_STEP_Lib.h>
#include <TimerOne.h>
Lib_LV8548Step Lib;
void setup()
{
  Serial.begin(19200);
  Lib.initLib();
  Timer1.initialize(10);
  Timer1.attachInterrupt(interrupt);
  delay(5000); →Note
  Lib.setStepAngle(1.8);
  delay(0);//0msec
  Lib.motorRotationDeg(666.6667, 180.0, 1, 1);
  delay(5000);//0msec
  Lib.motorRotationStep(1333.333, 400, 1, 1);
  delay(5000);//0msec
  Lib.motorRotationTime(2000, 8, 1, 1);
  delay(0);//0msec
  Lib.motorRotationFree();
  delay(0);//0msec
}
```

“motorRotationDeg(666.6667, 180.0, 1, 1)” will start the motor with an angle of 180[deg]
“delay(5000)” will drive the motor for 5000[msec] (5s)

After the time specified in the delay command has elapsed, the next command will be executed.

If the delay setting is 0 or too short, some motor operations will complete so quickly, that it will be imperceptible.

Note: The delay setting at the beginning of the setup method will execute in the case of a new USB connection, Arduino reset, or upon uploading a sketch to the Arduino. In this case, the Arduino will delay for 5 seconds while writing the initial settings.

*Some screen captures are taken from different motor driver modules

LV8548MCSLDGEVB for Stepper motor

Board Schematics (1/2)

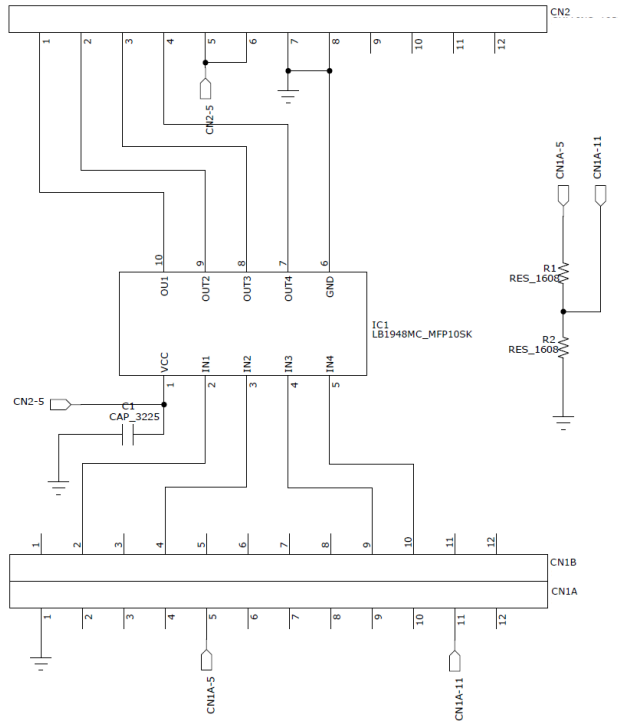

LV8548MCSLDGEVB Schematic

LV8548MCSLDGEVB Bill of Materials

Designator	Qty.	Description	Value	Tolerance	Footprint	Company	Part Number
IC1	1	Motor Driver	-	-	MFP10SK	ON Semiconductor	LV8548MC
R1	1	Thick Film Resistor	TBD	±5%	1608(0603Inch)		
R2	1	Thick Film Resistor	TBD	±5%	1608(0603Inch)		
C1	1	VCC Bypass Capacitor	10µF, 50V	±20%	3225(1210Inch)	Murata Manufacturing	GRM32ER71H106KA12L
CN1A, 1B	1	Pin header to baseboard	12 pins x 2	-	30.48 x 5.08	Würth Electronik	61301221121
CN2	1	Pin header to baseboard	12 pins	-	30.48 x 2.54	Würth Electronik	61301211121
PCB	1	PCB	-	-	30.48 x 20.32		

Parts highlighted in yellow are not mounted at the time of product shipment.

LV8548MCSLDGEVB for Stepper motor

Board Schematics (2/2)

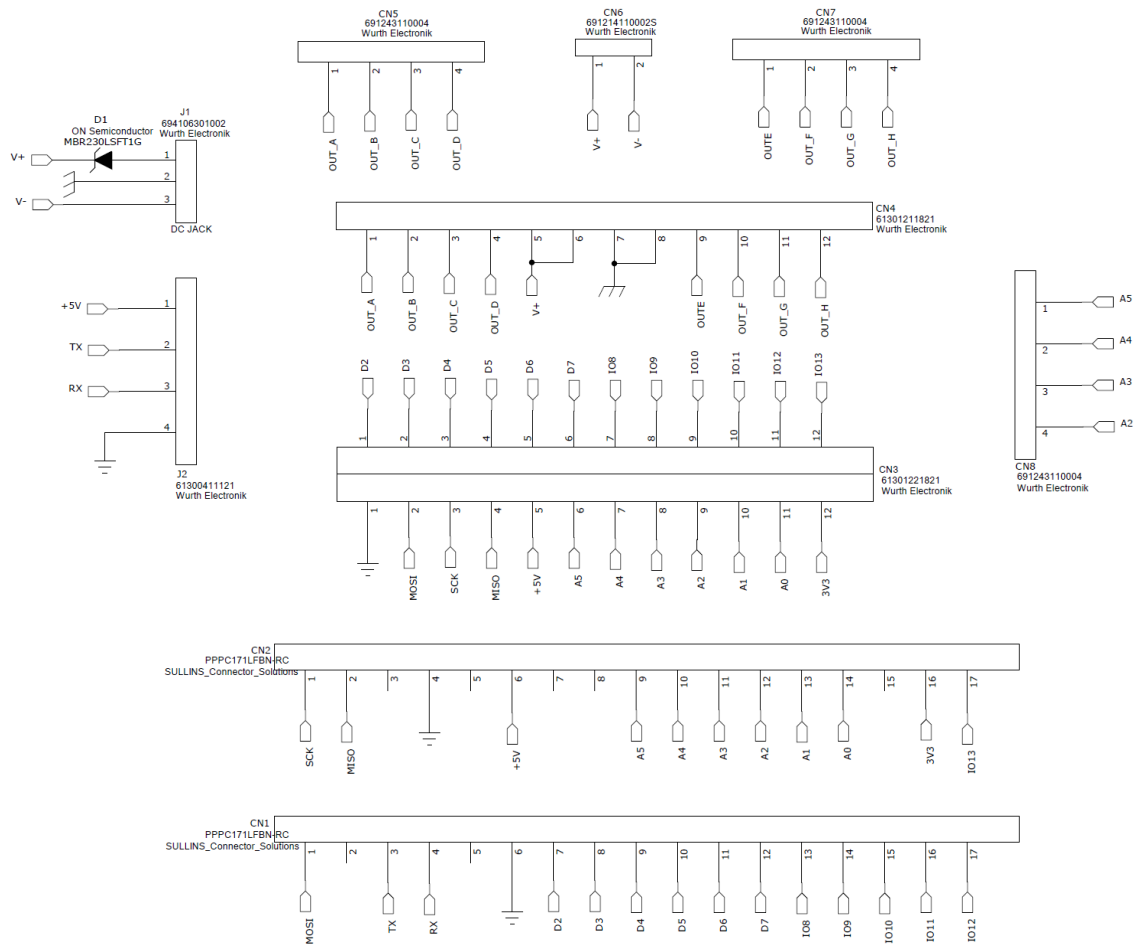

ONBB4AMGEVB Board Schematic

Baseboard Bill of Materials

Designator	Qty.	Description	Value	Tolerance	Footprint	Company	Part Number
D1	1	Diode	-	-	SOD123	ON Semiconductor	MBR230LSFT1G
CN1,2	2	Arduino Micro connector	-	-	Φ1.02 x17 -2.54 pitch	SULLINS connector solutions	PPPC171LFBN-RC
CN3	1	Module connector	-	-	Φ1.02 x12 x2lines -2.54 pitch	Wurth Elektronik	61302421821
CN4	1	Module connector	-	-	Φ1.02 x12 -2.54 pitch	Wurth Elektronik	61301211821
CN5,7,8	3	Motor connectors	-	-	Φ1.1 x4 -3.5 pitch	Wurth Elektronik	691243110004
CN6	1	Power connectors	-	-	Φ1.1 x2 -3.5 pitch	Wurth Elektronik	691214110002S
J1	1	DC barrel jack	-	-	9.0 x 14.5	Wurth Elektronik	694106301002
J2	1	UART pin headers	-	-	Φ1.1 x4 -2.54 pitch	Wurth Elektronik	61300411121
C1	1	Electrolytic capacitor	100μF, 50V	±10%	-	Wurth Elektronik	860020674015
PCB	1	PCB	-	-	80 x 60		

When using a custom-made baseboard, be sure to **mount an electrolytic capacitor equivalent to C1 between VCC and GND**. Neglecting to install this capacitor may lead to damage and malfunction of any connected driver modules.