

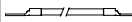

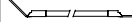





INSTALLATION INSTRUCTIONS T-PMPI-279-PC

© PANDUIT Corp. 2006

PZCGK	
	1
Door Jumper	
	1
Main Jumper	
	1
Cleaning Pad	
	1
12 – 24 Screw	
	2
12 – 24 HDW	
	6
12 – 24 HDW	
	3
Lock Washer	
	2
10 – 32 Screw	
	3
AntiOx	

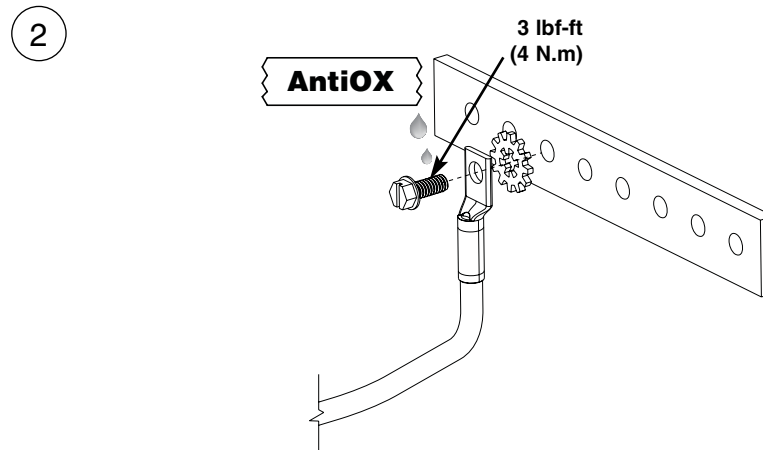
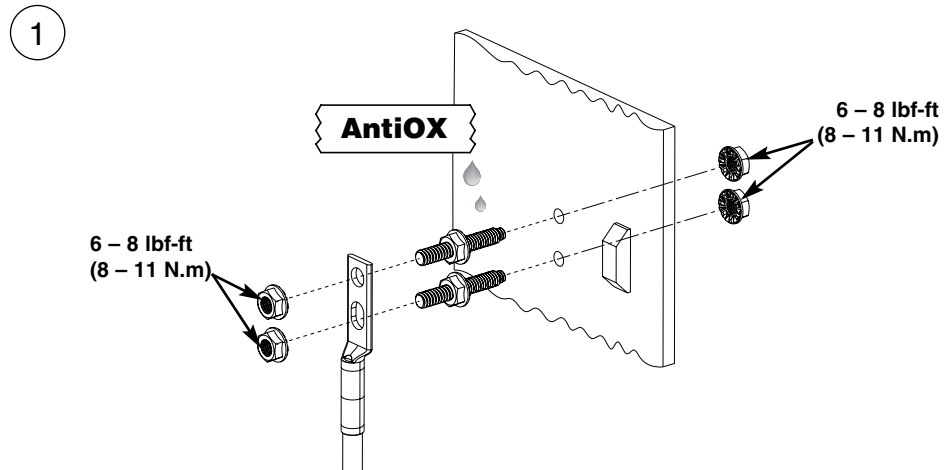
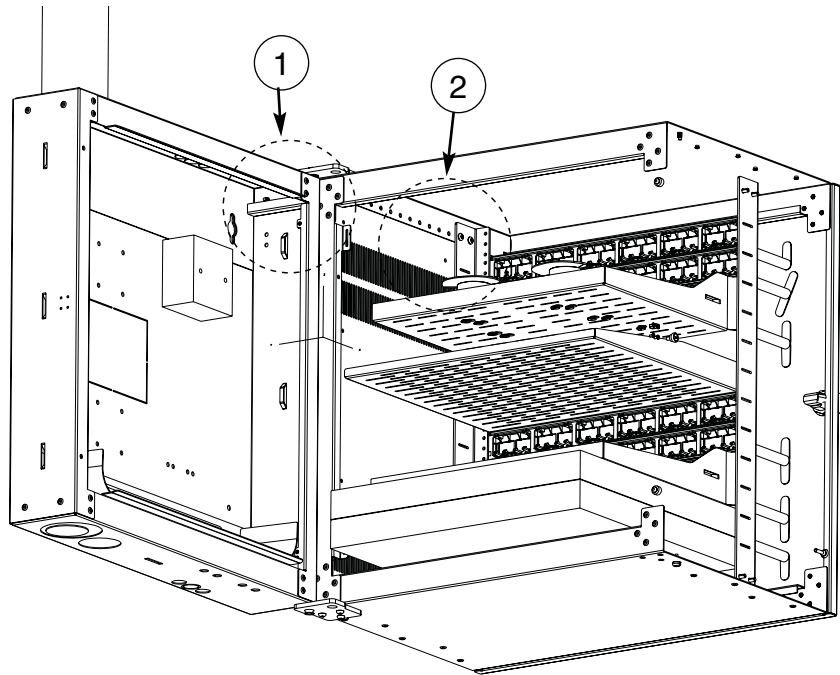

All torque values are based on a maximum Equipment Rail coating of .003".

For Technical Support: www.panduit.com/resources/install_maintain.asp

INSTALLATION INSTRUCTIONS T-PMPI-279-PC

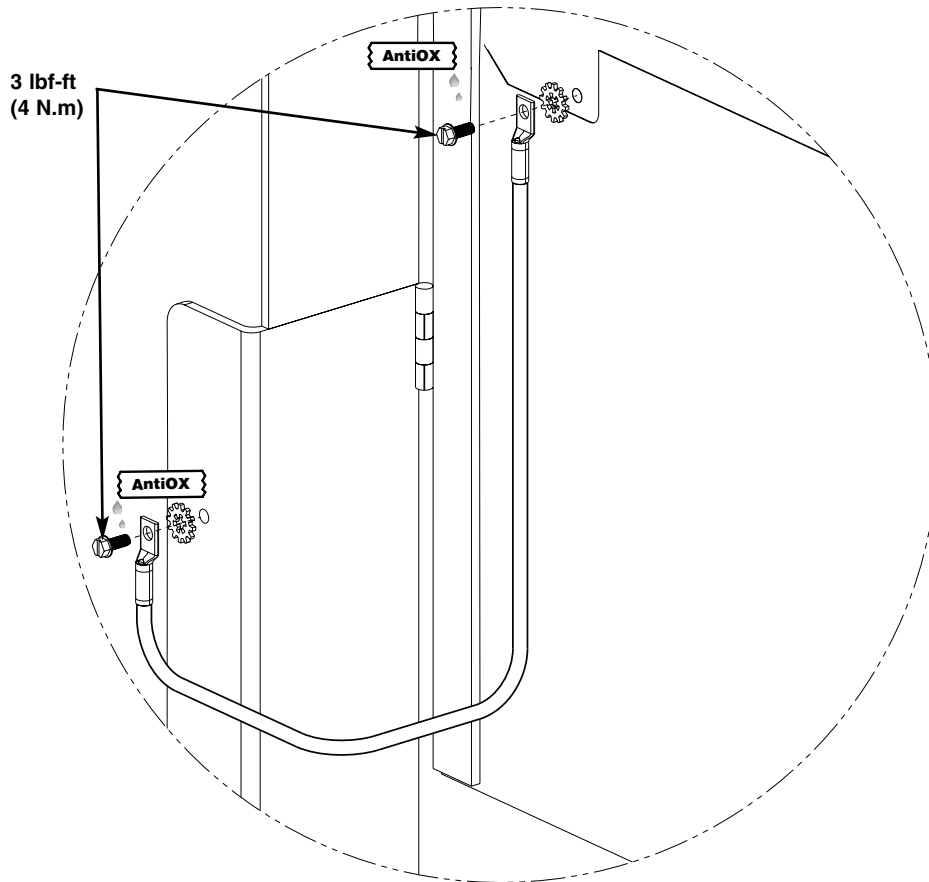
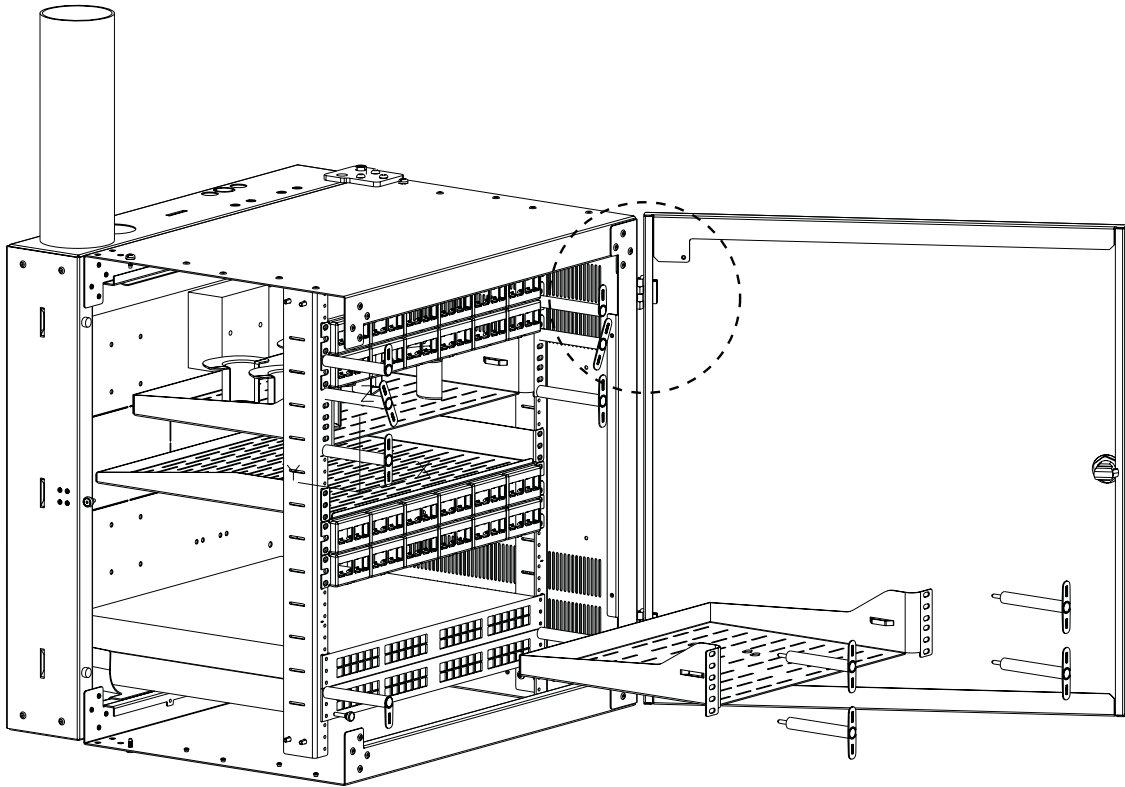

For Instructions in Local Languages
and Technical Support:

http://www.panduit.com/resources/install_maintain.asp



www.panduit.com

E-mail:
cs@panduit.com

Fax:
(815)485-5839